

A-A

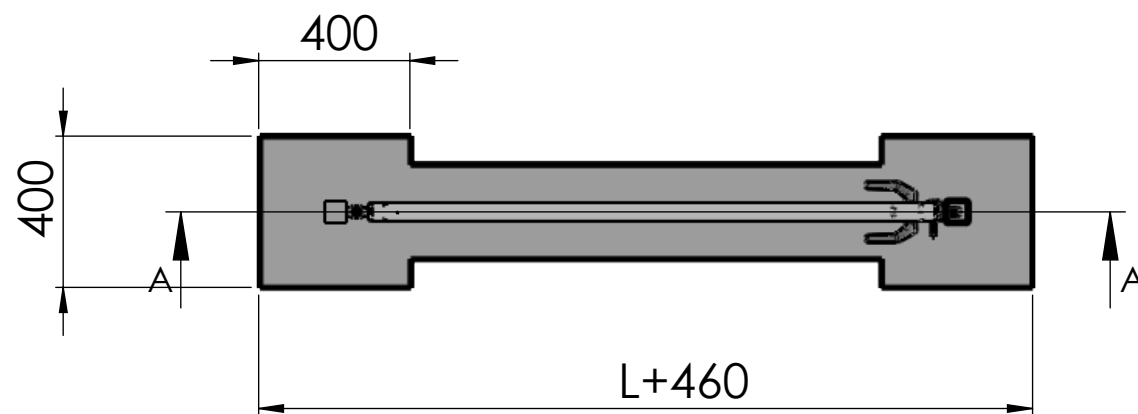

	H	PH	L
BRAMA 1,5M 150 ZN	1500	1560	1585
BRAMA 1,5M 170 ZN	1700	1760	1585
BRAMA 1,5M 190 ZN	1900	1960	1585
BRAMA 2M 150 ZN	1500	1560	2085
BRAMA 2M 170 ZN	1700	1760	2085
BRAMA 2M 190 ZN	1900	1960	2085
BRAMA 1,5M 120 ZN	1200	1260	1585
BRAMA 1,5M 140 ZN	1400	1460	1585
BRAMA 1,5M 160 ZN	1600	1660	1585
BRAMA 1,5M 180 ZN	1800	1860	1585
BRAMA 1,5M 200 ZN	2000	2060	1585
BRAMA 2M 120 ZN	1200	1260	2085
BRAMA 2M 140 ZN	1400	1460	2085
BRAMA 2M 160 ZN	1600	1660	2085
BRAMA 2M 180 ZN	1800	1860	2085
BRAMA 2M 200 ZN	2000	2060	2085
BRAMA 2M 150 CZ	1500	1560	2085
BRAMA 2M 170 CZ	1700	1760	2085
BRAMA 2M 190 CZ	1900	1960	2085
BRAMA 2M 120 CZ	1200	1260	2085
BRAMA 2M 140 CZ	1400	1460	2085
BRAMA 2M 160 CZ	1600	1660	2085
BRAMA 2M 180 CZ	1800	1860	2085
BRAMA 2M 200 CZ	2000	2060	2085